

# Drop Lock Installation Instructions

The Engineered Drop Lock flooring can be installed over most subfloors and is constructed to be dimensionally stable, making it suitable for installation over all grade levels. See all information and installation guidelines below.

## ATTN: INSTALLERS - CAUTION: WOOD DUST

Sawing, sanding and machining wood products can produce wood dust. Airborne wood dust can cause respiratory, skin and eye irritation. The International Agency for Research on Cancer (IARC) has classified wood dust as a nasal carcinogen in humans.

Precautionary Measures: Power tools should be equipped with a dust collector. If high dust levels are encountered, use an appropriate NIOSH-designated dust mask. Avoid dust contact with skin and eyes.

First Aid Measures in case of irritations: Flush eyes and skin with water for at least 15 minutes.

## WARNING! DO NOT MECHANICALLY CHIP OR PULVERIZE EXISTING RESILIENT FLOORING, BACKING, LINING FELT, ASPHALTIC "CUTBACK" ADHESIVES OR OTHER ADHESIVES.

These products may contain either asbestos fibers and/or crystalline silica. Avoid creating dust. Inhalation of such dust is a cancer and respiratory tract hazard. Smoking by individuals exposed to asbestos fibers, greatly increases the risk of serious bodily harm. Unless positively certain that the product is a non-asbestos containing material, you must presume it contains asbestos. Regulations may require that the material be tested to determine asbestos content and may govern the removal and disposal of material. See current edition of the Resilient Floor Covering Institute (RFCI) publication "Recommended Work Practices for Removal of Resilient Floor Coverings" for detailed information and instructions on removing all resilient covering structures.

## IMPORTANT HEALTH NOTICE:

THESE BUILDING MATERIALS EMIT FORMALDEHYDE. EYE, NOSE, AND THROAT IRRITATION, HEADACHE, NAUSEA AND A VARIETY OF ASTHMALIKE SYMPTOMS, INCLUDING SHORTNESS OF BREATH, HAVE BEEN REPORTED AS A RESULT OF FORMALDEHYDE EXPOSURE. ELDERLY PERSONS AND YOUNG CHILDREN, AS WELL AS ANYONE WITH A HISTORY OF ASTHMA, ALLERGIES, OR LUNG PROBLEMS, MAY BE AT GREATER RISK. RESEARCH IS CONTINUING ON THE POSSIBLE LONGTERM EFFECTS OF EXPOSURE TO FORMALDEHYDE. REDUCED VENTILATION MAY ALLOW FORMALDEHYDE AND OTHER CONTAMINANTS TO ACCUMULATE IN THE INDOOR AIR. HIGH INDOOR TEMPERATURES AND HUMIDITY RAISE FORMALDEHYDE LEVELS. WHEN A HOME IS TO BE LOCATED IN AREAS SUBJECT TO EXTREME SUMMER TEMPERATURES, AN AIR-CONDITIONING SYSTEM CAN BE USED TO CONTROL INDOOR TEMPERATURE LEVELS, OTHER MEANS OF CONTROLLED MECHANICAL VENTILATION CAN BE USED TO REDUCE LEVELS OF FORMALDEHYDE AND OTHER INDOOR AIR CONTAMINANTS. IF YOU HAVE ANY QUESTIONS REGARDING THE HEALTH EFFECTS OF FORMALDEHYDE, CONSULT YOUR DOCTOR OR CALL LOCAL HEALTH DEPARTMENT.

**ATTENTION: IT IS THE INSTALLER/OWNER RESPONSIBILITY** - Inspect **ALL** materials carefully BEFORE installation. Wood is a natural product containing natural characteristics such as variations in color, tone and graining. Some variation in color is to be expected in a natural wood floor. Even though our product goes through many inspections before it leaves the plant, it is the customer and installer's responsibility for final inspection prior to installation. The warranty DOES NOT cover materials with visible defects once they are installed.

## TOOLS

Basic tools and accessories: broom or vacuum, chalk line, tapping block, pull bar, hammer, wood flooring surface cleaner, hand or electric jam saw, miter saw, moisture meter, safety glasses, straight edge, table saw, tape measure, square, utility knife, pry bar, PVA wood glue and underlayment with attached moisture barrier.

**Caution:** Don't use a rubber mallet to engage the locking system. Use a tapping block instead. A rubber mallet hitting any finished surface will cause abrasive marks (dull spots) and chipped edges.

## JOBSITE CONDITIONS

The room temperature should be 60 - 80° F, with relative humidity of 35 - 60%. These environmental conditions are specified as pre-installation requirements and should be maintained for the life of the engineered wood.

It is the responsibility of the installers/owner to determine if the job site subfloor and job site conditions are environmentally and structurally acceptable for wood floor installation. The manufacturer declines any responsibility for wood failure resulting from or connected with subfloors, subsurface, job site damage or deficiencies after hardwood flooring has been installed.

## SUBFLOOR PREPARATION AND RECOMMENDATIONS FOR ALL INSTALLATIONS

### Concrete Subfloors

New concrete slabs require a minimum of 60 days drying time before covering them with a wood floor.

Concrete subfloors must be dry, smooth (level within 3/16" in a 10' radius 1/8" in 6') and free of structural defects. Hand scrape or sand with a 20-grit #3-1/2" open face paper to remove loose, flaky concrete. Grind high spots in concrete and fill low spots with a Portland based leveling compound (min. 3,000 psi). Concrete must be free of paint, oil, existing adhesives, wax, grease, dirt and curing compounds. These may be removed mechanically but do not use solvent-based strippers under any circumstances. The use of residual solvents can prohibit the satisfactory bond of flooring adhesives. It is important to ensure a proper bond between the adhesive and the concrete, and planks or strips. Engineered hardwood flooring may be installed on-grade, above grade, as well as below grade where moisture conditions are acceptable.

### Light Weight Concrete

Light weight concrete that has a dry density of 100 pounds or less per cubic foot is only suitable for engineered wood floors when using the floating installation method. Many products have been developed as self-leveling toppings or floor underlayments. These include cellular concrete, resin-reinforced cementation underlayments, and gypsum-based materials. Although some of these products may have the necessary qualifications of underlayment for wood flooring installations, others do not. To test for lightweight concrete, scrape a coin or key across the surface of the sub floor. If the surface powders easily or has a dry density of 100 pounds or less per cubic foot, use only the floating installation method.

### Wood Subfloors

Wood subfloors need to be well nailed or secured with screws. Nails should be ring shanks and screws need to be counter sunk. The wood subfloor needs to be structurally sound and dry. It should not exceed 13% moisture prior to installation. If the subfloor is single layer, less than 3/4" thick, add a single cross layer for strength and stability (minimum 5/16" thick for a total 1" thickness). This is to reduce the possibility of squeaking. Wood sub-floors must be free of paint, oil, existing adhesives, wax, grease, dirt, urethane, varnish, etc. Underlayment grade OSB (not the wax side) is also a suitable sub-floor. **Particleboard is not an acceptable sub-floor for staple or nail down installations** but can be used as a subfloor in glue-down installations. When installing over existing wood flooring, install at right angles to the existing floor.

### Subfloor Moisture Check

Engineered hardwood flooring may be used for above, on, and below grade applications and on all common substrates, on and below grade applications are susceptible to moisture and should be tested for moisture prior to installation in several locations within the installation area. Acceptable conditions for above-on-and below grade applications are:

- Less than 3 lbs. /1000 SF / 24 hrs. on a calcium chloride test.
- Or an acceptable reading on an electronic concrete moisture meter.
- Wood substrates must have a moisture reading of less than 13% when using an electronic wood moisture meter.

To correct any subfloor problems concerning moisture, either wait until the subfloor dries to meet specifications or use an appropriate moisture barrier.

### Radiant Heated Subfloors

Prior to the installation of engineered hardwood flooring over a radiant heated flooring system the following guidelines must be followed in order to prevent unsatisfactory results for the flooring.

Previously noted concrete subfloor requirements will apply.

It is highly recommended that the radiant heat system be designed to accept a wood floor.

**Use only the floating installation method.**

Relative humidity of the jobsite must be maintained between 35 – 60%. Use of a humidification system may be required to maintain the proper humidity level. Failure to maintain the humidity range noted can result in excessive dryness of the flooring which may lead to surface checking.

The radiant heat system should be set to run at 2/3 maximum output for a minimum of 2 weeks prior to installation of flooring to further allow moisture dissipation from the concrete slab. This must be done in both warm and cold seasons.

Before installation (5 days) reduce the temperature to 65°F and maintain temperature range of 64 - 68°F during the installation.

After completion of the installation, wait 48 hours and then gradually raise the temperature of the heating system 2 - 3° per day over a five day period until the preferred setting is reached.

**Caution:** The floor surface must never exceed 80° F in temperature.

Room temperature should not vary more than 15° from season to season.

Seasonal gapping should be expected.

*Please note: A radiant heat system will dry out all woods. Therefore, the home MUST maintain a year-round relative humidity of 35-60%. If you are unable to maintain proper humidity year-round, do not install the flooring. The warranty will not cover extreme heat or dryness*

### Subfloors other than Wood or Concrete

**Note:** Perimeter glued resilient vinyl and rubber tiles are unacceptable underlayments and must be removed.

Terrazzo, tile and any other hard surfaces that are dry, structurally sound and level, as described above, are suitable as a subfloor for installation of engineered hardwood flooring. As above, the surface must be sound, tight and free of paint, oil, existing adhesives, wax, grease and dirt. Terrazzo and ceramic tile must be scuffed to assure adhesion.

**Warning!** Do not sand existing resilient tile, sheet flooring, and backing or felt linings. These products may contain asbestos fibers that are not readily identifiable. Inhalation of asbestos dust can cause asbestosis or other serious bodily harm. Check with local state and federal laws for handling hazardous material before attempting the removal of these floors.

### PREPARATION

Remove all moldings and wall-base, and undercut all door casings with a hand or power jam saw using a scrap piece of flooring as a guide.

"Racking the Floor"

Start by using random length planks from the carton or by cutting four to five planks in random lengths, differing by at least 6". As you continue working across the floor, be sure to maintain the 6" minimum between end joints on all adjacent rows. Never waste material; use the left over pieces from the fill cuts to start the next row or to complete a row.

**Note:** When installing a pre-finished wood floor be sure to blend the wood from several cartons to ensure a good grain and shading mixture throughout the installation.

Always stagger boards 12" – 24" between end joints of adjacent board rows.

The last row should never be narrower than 2".

## INSTALLING AS A FLOATING FLOOR

### Subfloor Preparation:

Preparation of a subfloor is critical for a floating engineered floor. The sub-floor must be flat to 3/16" in a 10' radius. If the floor requires correction, the high areas can be ground down and the low areas may be filled by floating latex fortified Portland leveling compound. The leveling compound must be allowed to dry according to the manufacturer's instructions before the floor is installed over it. The use of sand or extra padding to fill low areas is not acceptable.

Important: Do not install cabinets or walls on top of the flooring when using the floating installation method.

### Underlayment

Floating installation requires the use of poly-foam underlayment designed for engineered hardwood floating floors, with a minimum thickness of 1/8" and a 2.0# density. Underlayment requirements are very critical in a floating installation. Excessive pad compression or compaction is a common cause of seam failure. Underlayment should be installed perpendicular to the direction of the flooring (Figure 1). Butt ends together and do not overlap. Tape seams with duck tape.

### Getting Started

**Begin installation of the first row by selecting the longest length board available.** The first board should be placed on the right side of the room with the long direction parallel to the wall. Recommended to use the longest wall in the room. If necessary, cut the first row lengthwise to ensure that the last row will not have a width of less than 2".

Start by placing the tongue side of the first board towards the wall.

Insert spacers between the wall and the first board to ensure an expansion gap of 1/2" along the wall (Figure 2). Expansion gap may vary due to irregularities in the wall.

Align the next board and drop the end joint into place against the end of the first board, interlocking the tongue and groove by pushing down. Some slight adjustment of the board may be necessary to assure a proper fit that is in line with the initial board. Again, place spacers as necessary to minimize movement.

**Continue as previously noted until first row has been completed. Cut the last board in the row to length (allowing for expansion space on the end) and drop it into place.**

### Installing Remaining Rows

Begin the second row with the cut piece from the first row. If the cut piece is shorter than 8", do not use it. Instead, begin with a new board that exceeds 8" length and allows at least 6" of spacing between the end joints.

Place the first board in place by angling it up slightly, pushing forward and interlocking the side tongue (Figure 3). Carefully push the board down until the tongue and groove locks together. A slight tap with a nylon-tapping block may be required.

Continue installing all remaining boards in the same manner noted above, ensuring at all times, that planks are laid with their end joints staggered by at least 6".

Do not forget to insert a spacer at the beginning and end of each row to ensure the correct expansion gap and also to act as a brace to allow you to tap the short ends into place when necessary. Under no circumstances should the board edges be hit directly by a mallet or hammer – always use a tapping block.

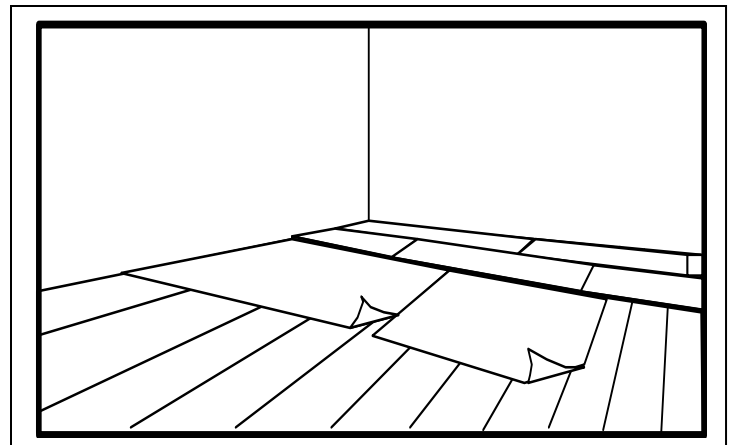

Figure 1

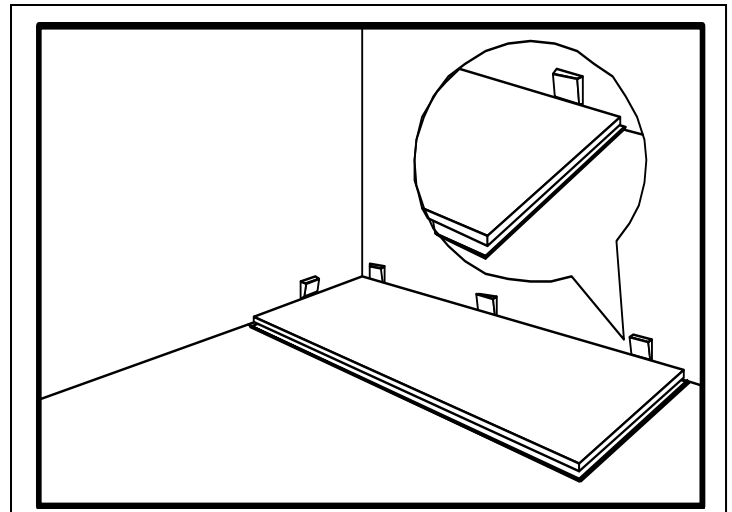

Figure 2

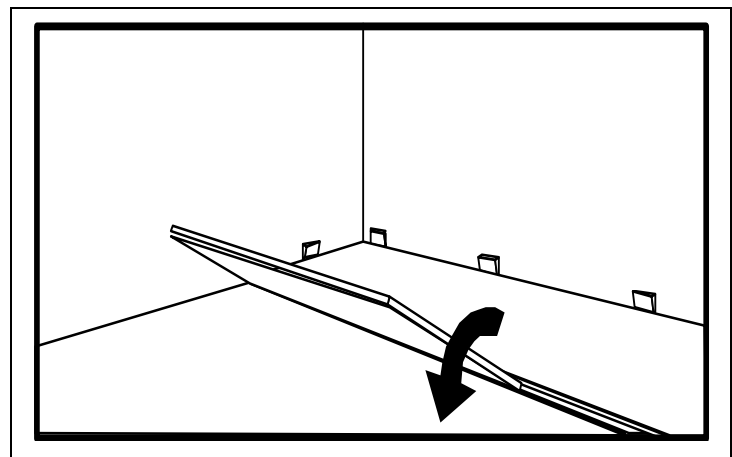

Figure 3

### Installing the Last Row

The last row of boards might have to be cut lengthwise to fit. If necessary, place a board on the second-to-last row of boards and scribe the cutting line (Figure 4) - **Do not forget to allow for the expansion gap.** After the last row has been cut, lock the board into place using the pull bar (Figure 5).

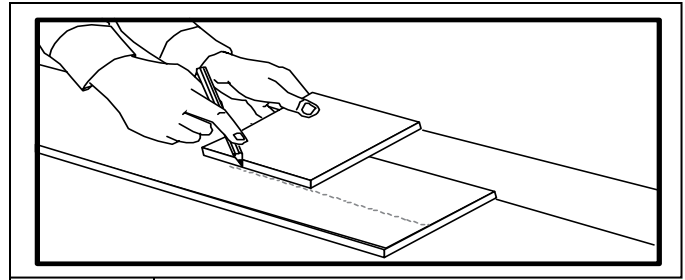

Figure 4

### Installing Under a Door Frame

If fitting part of the last row under a doorframe, you will first have had to shave off the bottom cheek of the groove on the previous row (Figure 6). Doing this will allow you to slide the last row under the door frame and then, having applied a bead of PVA wood glue into the groove, tap this board back into the groove using a tapping block and/or pull bar. This will ensure a solid joint in this area while also allowing you to neatly finish the doorframe area. This system can also be used where the last row is fitted under a radiator for example.

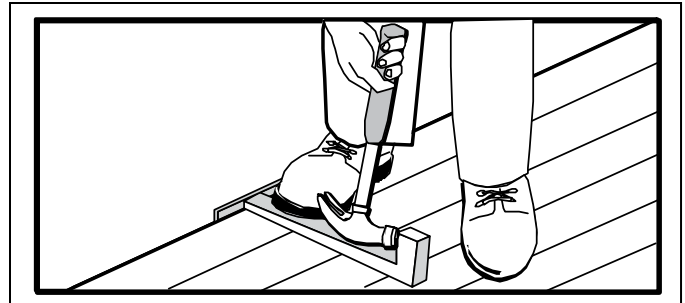

Figure 5

### Installing Near Pipes

**Figure 7:** To drill holes for heating pipes, use a bit at least 3/4" wider than the diameter of each pipe.

**Figure 8:** Cut holes as illustrated.

**Figure 9:** Glue the cut piece in place. Fit pipe collars around the pipes.

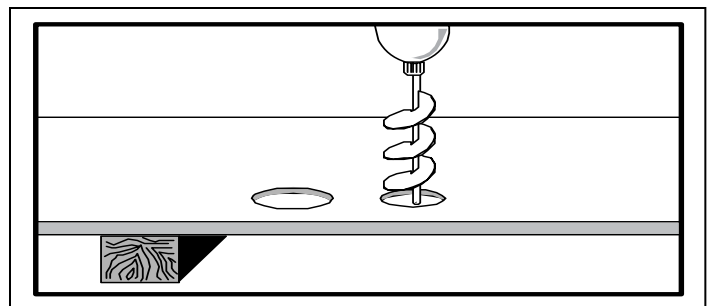

Figure 7

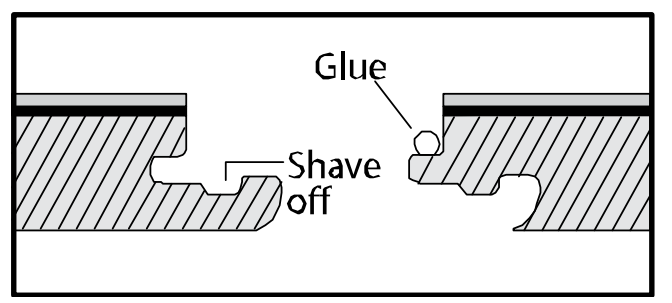

Figure 6

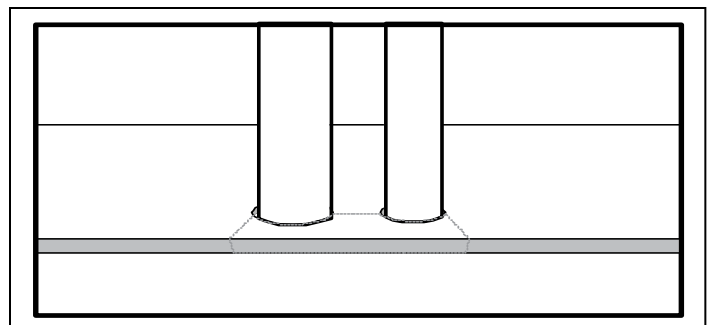

Figure 9

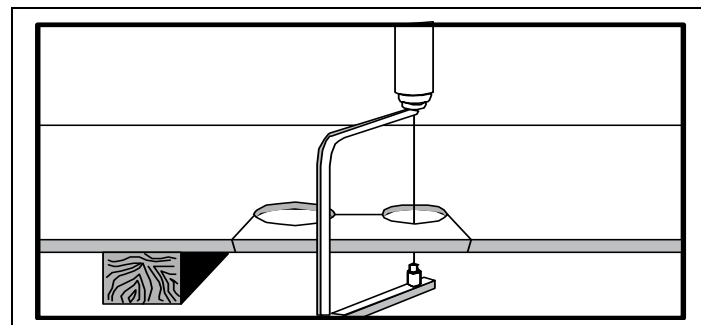

Figure 8

### Completing the Installation

- Remove all wedges.
- Install any transition pieces that may be needed, such as reducer strips, T-moldings, or thresholds.
- Re-install all base and/or quarter round moldings. Nail moldings into the wall, not the floor.
- Clean floor.
- Do not cover the floor with a non-breathable material such as plastic.
- To prevent surface damage avoid rolling heavy appliances or furniture on the floor without sufficient protection.

## GLUE DOWN INSTALLATION GUIDELINES

There several ways to install using a glue down method such as wet lay or tacked. Caution: It is important to follow all guidelines set by the adhesive manufacturer for the glue down method you choose. By not adhering to the guidelines you can void your flooring warranties.

### Step 1:

Select a starter wall. It is recommended to start the installation along an exterior wall; it's more likely to be straight and square with the room. Measure out from the wall the width of two strips plus 1/4" and mark each end of the room and snap your chalk line.

### Step 2:

Spread "adhesive" from the chalk line to the starter wall using the adhesive manufacturer's recommended trowel. It is important to use the correct trowel at an angle to get the proper spread of adhesive applied to the sub-floor, which will produce a proper and permanent bond. Improper bonding can cause loose or hollow spots. Note: Change the trowel every 2000 to 3000 square feet due to wear down of the notches. This assures you always get the proper spread of adhesive.

### Step 3:

Install the first row of starter strips with the tongue facing the starter wall and secure into position. Alignment is critical and can be achieved by top nailing the first row with finishing nails (wood installation instructions: engineered floor sub-floor), or sprig/pin nails (concrete sub-floor). This prevents slippage of the strips that can cause misalignment. Note: The strips along the wall may have to be cut to fit since most walls are not straight, and leaving an expansion space is not necessary with engineered wood strips installed with the glue-down method.

### Step 4:

Once the starter rows are secure, spread 2-1/2 to 3 feet of adhesive the length of the room. (Never lay more adhesive than can be covered in approximately 2 hours.) Place the tongue into the groove of the strips and press firmly into adhesive. Never slide strips through adhesive. Test for proper bond by occasionally lifting a board and looking for good coverage (90%), and then replace it into the adhesive. Clean any adhesive off the surface before it cures using water. Use mineral spirits after it cures.

### Note:

*Never work on top of the flooring when installing with a glue down method. Light foot traffic is allowed after 12 hours but wait 24 hours after installation.*

## MAINTENANCE

Engineered Hardwood Floors are very easily maintained. No wax, no mess. Simply use a cleaner made for use with urethane coated hardwood floors and a terry cloth flooring mop.

**STEP ONE:** Sweep your floor to remove any particles that could scratch your floor.

**Warning:** Vacuums with a beater bar or power rotary brush head can damage a wood floor and never should be used.

**STEP TWO:** Apply hardwood surface cleaner directly to the terry cloth flooring mop, instead of the floor!

**STEP THREE:** Use a back and forth motion with the mop. When the terry cloth cover becomes soiled, simply replace it with a clean one. Cleaning the floor with a soiled cover could cause streaking. The covers are re-usable, so wash and dry the covers periodically as you would a normal towel.

### Tips & Warnings – Neglect will void the warranty

- **Maintain a normal indoor relative humidity level (35 – 60 %) throughout the year to minimize the natural expansion and contraction of the wood.**
  - I. **Heating Season (Dry):** A humidifier is recommended to prevent excess shrinkage due to low humidity levels. Wood stoves and electric heat tend to create very dry conditions.
  - II. **Non Heating Season (Wet):** An air conditioner, dehumidifier, or periodically turning on your heating will help to maintain humidity levels during summer months.
- Sweep regularly.
- Remove spills promptly using wood flooring cleaner and a clean white cloth.
- Use felt protectors under heavy pieces of furniture and chairs.
- Use protective mats at all exterior entrances.
- Spiked heels or shoes in need of repair can severely damage your floor.
- Never wet or damp mop your wood floors. Water can cause damage to wood flooring.
- Never use oil soaps, wax, abrasive cleaners, steel wool or strong ammoniated or chlorinated type products to clean your floor.
- The sun's UV rays can change the color of your floor.
- Keep animal nails trimmed.
- Protect your floor with a 1/4" piece of plywood or Masonite when using a dolly for moving furniture or appliances. **Never slide or roll heavy furniture or appliances across the floor.**
- If your floor becomes scratched or dull, repairs can often be made using repair accessories.